



# BUTTERFLY VALVE

50MM - 300MM

All Valve  
INDUSTRIES



**W**  
WMTS-012  
C OF C 30027

LEVER SUPPLIED AS STANDARD  
UP TO 200MM AND WITH GEAR  
OPERATOR OVER 250MM

## WATERMARK APPROVED BUTTERFLY VALVES

### FUNCTION AND FEATURES

- Light weight and compact design reduces installation, storage and transport costs
- Max 1,600kPa inlet pressure, and -20°C to 110°C temperature range
- Each valve body is factory tested to 2,400kPa to ensure reliable performance
- Individually packaged for reduced damage in transport and storage
- Available in lugged Table 'E', or wafer design which suits multiple flange tables.
- Lever handles feature a lockable design as standard
- Corrosion resistant epoxy paint and 316SS disc ensure long service life.
- Top ISO 5211 mounting flanges allows for gearbox or actuator attachments.

## PRODUCT SPECIFICATIONS

The Arita butterfly valve is a soft sealing valve for installation with flanges drilled in accordance with AS 2129 Table E, available in sizes 50mm through to 300mm. The Arita butterfly valves are a high performance valve, designed for a long service life, and are priced competitively.

Arita products are engineered for long term maintenance-free performance. The lever handle is lockable as standard, and the valve features a top ISO mount allowing for gearbox or actuator connection, making this a versatile valve for a variety of applications and industries.

**The butterfly valves feature a push in style liner which allows it to be replaced. Due to this, they are not recommended for end of line service where only one side of the liner is supported by the pipe flange.**

- **A GEAR OPERATOR AND PNEUMATIC OR ELECTRIC ACTUATOR ARE AVAILABLE ON REQUEST.**
- **OTHER LINERS ARE AVAILABLE ON REQUEST INCLUDING NBR, PTFE & VITON (NON WATERMARK APPROVED)**
- **LARGER 350MM+ BUTTERFLY VALVES AVAILABLE (NON WATERMARK APPROVED)**

### TECHNICAL SPECIFICATIONS

MAX PRESSURE	1,600kPa
TEMPERATURE	-20°C - 110°C

## DIAGRAM

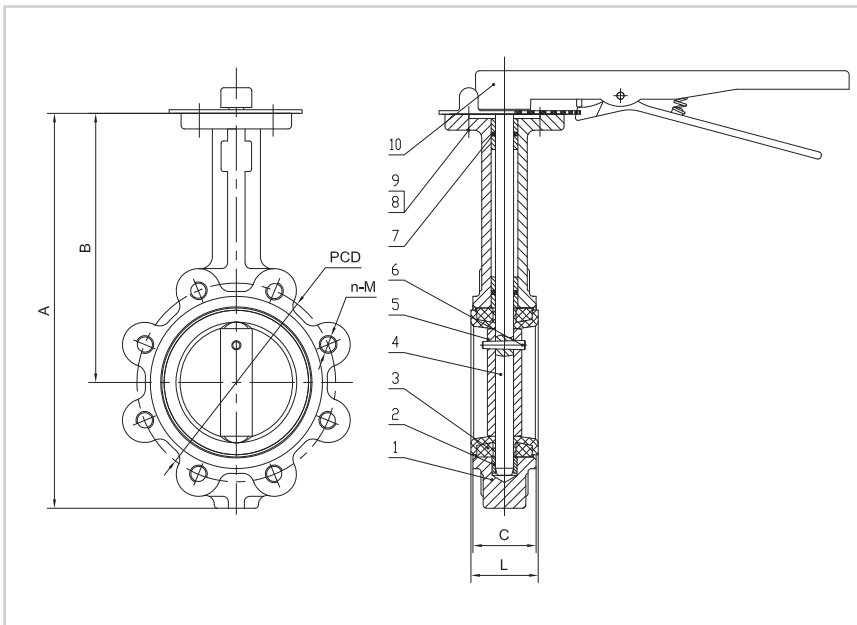

NO.	PART	MATERIAL
1	BODY	CI
2	BUSHING	PTFE
3	SEAT	EPDM
4	SHAFT	SS 416
5	DISC	SS 316
6	PINS	SS 316
7	O-RING	EPDM
8	BOLTS	SS 304
9	GASKETS	SS 304
10	LEVER	MAL. IRON

**SIZES UP TO 200MM SUPPLIED WITH LEVER OPERATORS AS STANDARD. 250MM+ SUPPLIED WITH GEAR OPERATORS.**

**GEAR OPERATORS ARE AVAILABLE FOR ALL SIZES.**

SIZE	LUGGED CODE	WAFER CODE	A	B	C	L	PCD	n-M
50MM	BLUG-050	BFLY-050	241	161	42	46.1	114	4-M16
65MM	BLUG-065	BFLY-065	264	175	45	49.1	127	4-M16
80MM	BLUG-080	BFLY-080	276	181	45	49.1	146	4-M16
100MM	BLUG-100	BFLY-100	314	200	51	55.3	178	8-M16
125MM	BLUG-125	BFLY-125	340	213	54.5	58.8	210	8-M16
150MM	BLUG-150	BFLY-150	370	226	54.5	59.1	235	8-M20
200MM	BLUG-200	BFLY-200	435	260	59.6	64.1	292	8-M20
250MM	BLUG-250	BFLY-250	494	292	67	72	356	12-M20
300MM	BLUG-300	BFLY-300	579	337	76	81	406	12-M24



040815-00